

DATA SHEET

iTherm® Core for engine
block casting

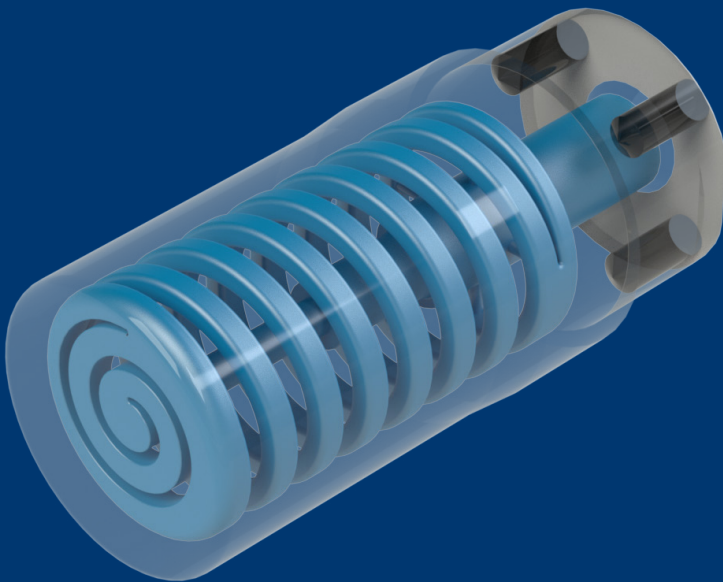

iTherm® Core for engine block casting

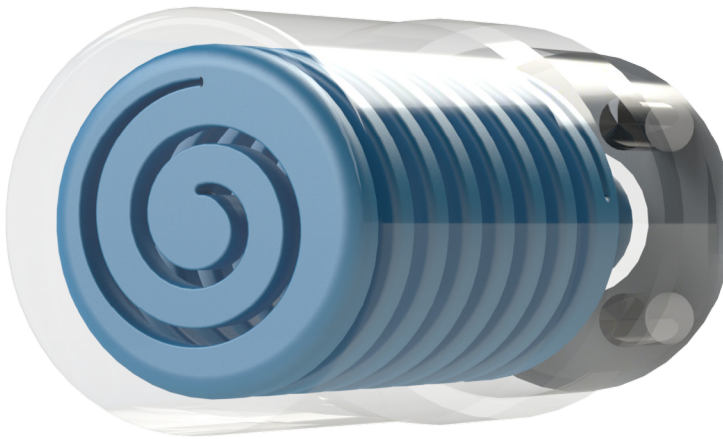

DESCRIPTION

iTherm Core is a die casting component used for engine block casting. It has specifically designed cooling arrangement, which brings uniform core temperature to desired level.

It is highly innovative conformal cooling single-body solution and proven-performer applied where optimum process solutions are required.

MAIN ADVANTAGES

- Temperature homogeneity of working surface
- Single body component, therefore no leakage is possible
- Cooling system arrangement designed to fit the desired product geometry.

iTherm® Core for engine block casting

GENERAL DIMENSIONS

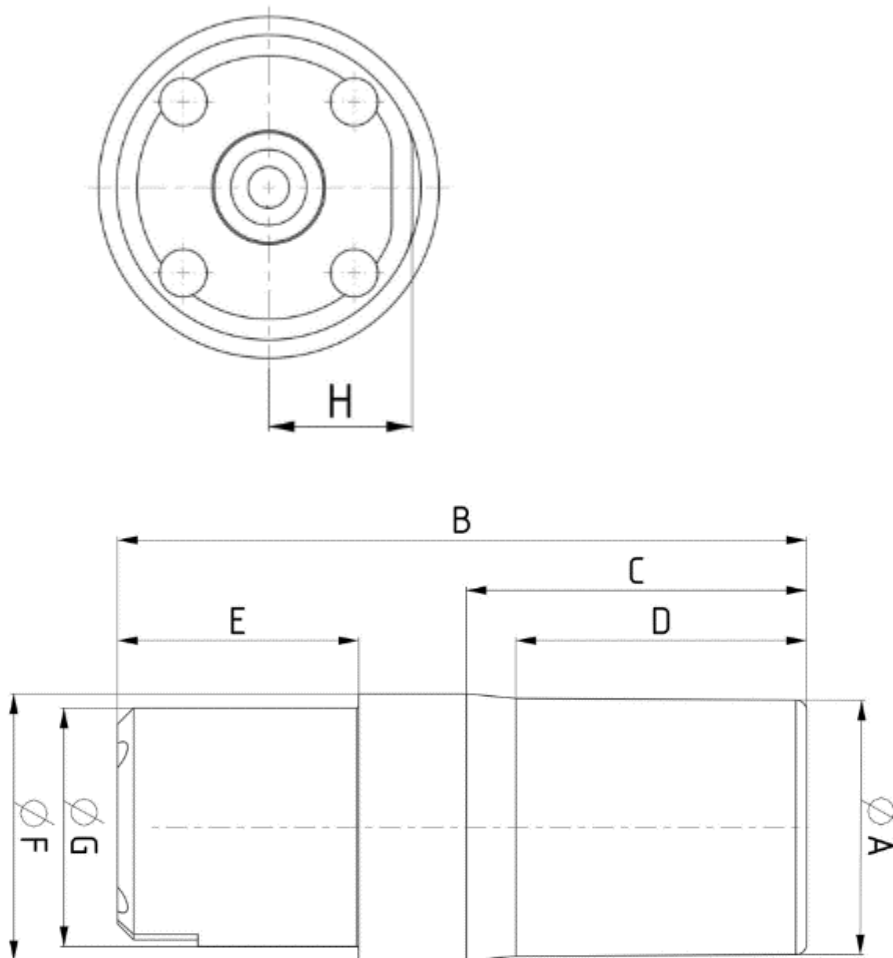

Parameter	Limit
ØA	55 - 135
B	150 - 295
C	60 - 160
D	60 - 160
E	40 - 130
ØF	40 - 130
ØG	55 - 135
H	(ØG-5) - ØG

All dimensions are in mm

iTherm® Core for engine block casting

CONNECTION HOLES

Connector hole is a bubbler design tube, always positioned in the middle of core. Both inlet and outlet connectors are connected in one flow with only one connector location. Type of connector can be chosen between ¼ NPT, 3/8 NPT, ½ NPT, 5/8 NPT, G1/4, G3/8, G1/2, G5/8.

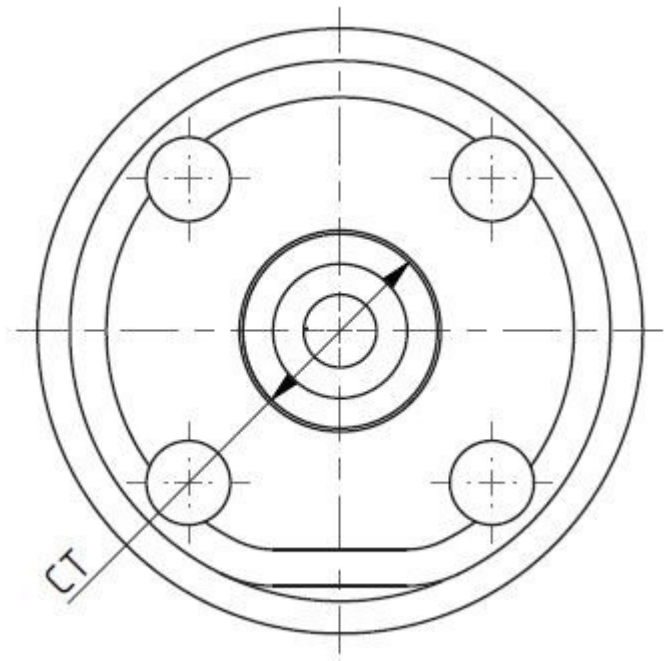

FASTENING HOLES

Selection of fastening holes is possible. Fastening holes can be positioned within ½ G and ¾ G dimension. Customer can select between M10, M12, M14, M16, ¼ - 20 UNC, 3/8 - 16 UNC, Ø10, Ø12, Ø14 fastening types, which can be in depth up to 40 mm.

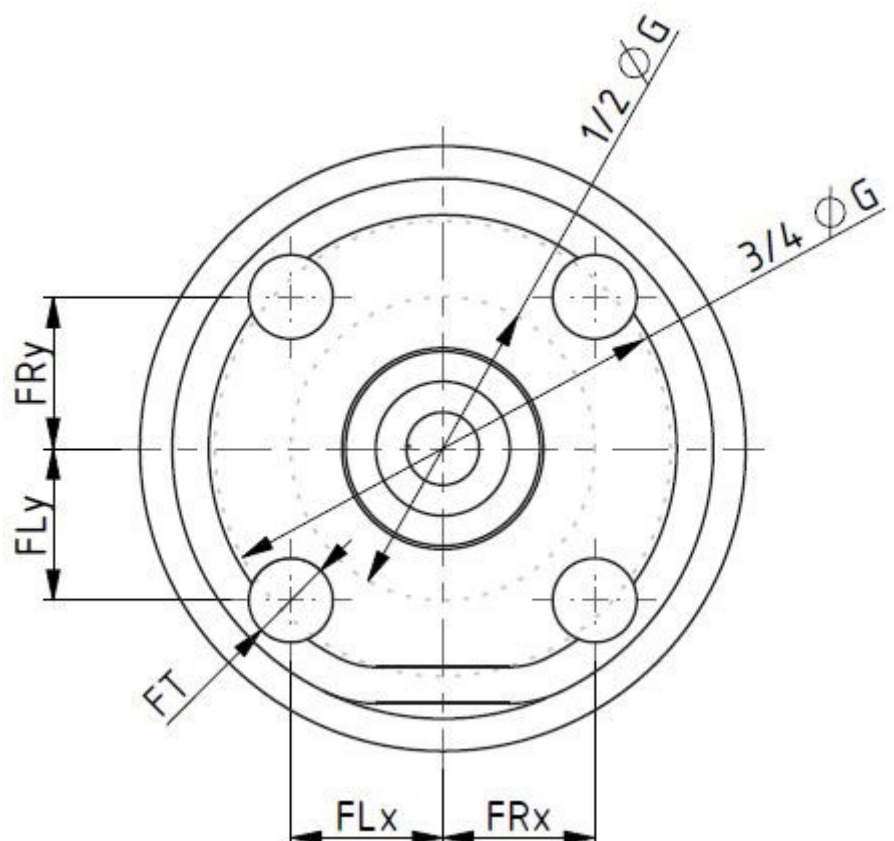

MATERIAL

A selection of material and material hardness is possible. Customer can choose between different types of hot work tool steel and material hardness per customer request. Additionally selection of surface nitriding is an option.

**iTherm® Core for engine
block casting**

**Do you need a slightly different
design or component?**

We got you covered.

Contact our die casting professionals and we will do our best to match your requirements. You can count on us to support you through each step of performance improvement.

sales@hts-ic.com